

Accurate Greenhouse Gas Measurements in Humid Gas Streams Using the Picarro G1301 Carbon Dioxide / Methane / Water Vapor Gas Analyzer

Chris Rella, Ph.D.
Director of Research & Development
Picarro, Inc., Sunnyvale, California
rella@picarro.com

Summary. Traditional techniques for measuring greenhouse gas inventories in the well-mixed atmosphere have required extremely dry sample gas streams (dew point < -60°C) to achieve the inter-laboratory comparability standard set forth by the WMO for carbon dioxide (100 ppb) and methane (2 ppb). Drying the sample gas to low water vapor levels can be both expensive and prone to problems, especially at remote sites where access is difficult. The Picarro G1301 three-species greenhouse gas analyzers for the first time permit accurate and precise greenhouse gas measurements that can meet the WMO inter-laboratory comparability standard *without* drying the sample gas. Below, we present direct measurements of the water vapor correction factors that, when applied to the G1301 data, enable dry gas mixing ratio measurements without the need for low-level drying or frequent calibration. In addition, we confirm these results with careful spectroscopic analysis, and we estimate the uncertainties remaining in the measurement of the dry gas mixing ratios.

Introduction

Traditional methods of measuring greenhouse gas inventories in the well-mixed atmosphere have relied upon NDIR (non-dispersive infrared) for carbon dioxide and GC (Gas Chromatography) for methane. Typically, these measurements are performed on dried gas streams for two reasons: a) the mixing ratios for carbon dioxide and methane are only meaningful when extrapolated back to dry-gas conditions – due to the volatility of the water vapor content in the atmosphere, the effect of dilution by water vapor^a needs to be removed before meaningful data are obtained; and b) it is not possible to achieve the overall inter-laboratory comparability stipulated by the WMO standard for CO₂ (100 ppb) and CH₄ (2 ppb) with these technologies without drying the samples to very low levels, in some cases to a dew point of lower than -60C (0.001 %v).

Given the fact that dry-gas measurements are the ultimate goal, it would seem to be appropriate to dry the samples prior to measurement. However, drying air samples to these levels introduce complexity to the sampling system, dramatically increase the surface area and gas fittings in the sampling system, and require the use of costly consumables that demand the frequent attention of

^a The dilution effect is simply the change in mixing ratio of carbon dioxide and methane caused by variability in the humidity. For example, a dry air mass traveling over warm water will accumulate humidity, and this additional water vapor will dilute the concentration of the other gases. Conversely, a humid air mass that becomes drier (as through precipitation) will cause an inverse dilution effect, increasing the mixing ratios of the other gases.

measurement station personnel. It would be a significant practical advantage to be able to measure *dry-gas* mixing ratios for carbon dioxide and methane directly in the *wet* gas stream. It has been impractical to make measurements in the wet gas stream, not only because traditional techniques suffer from significant cross-talk between water vapor and carbon dioxide and methane, but also because until the introduction of the Picarro G1301 three species analyzer, water vapor measurements of sufficient accuracy and precision have not been practical in the field. Because this analyzer directly measures the water vapor content of the air stream at the same time as carbon dioxide and methane, the dry gas mixing ratios of these two critically important greenhouse gases can be directly quantified with high precision and high accuracy, even in very humid gas streams.

The G1301 Analyzer is based on WS-CRDS (wavelength-scanned cavity ringdown spectroscopy), a rugged and robust all-optical technology that delivers unprecedented accuracy and precision in a compact, easy-to-use, field deployable package¹. The heart of the WS-CRDS analyzer is the optical cavity, a compact flow cell with a volume of just 35 cc's and an effective optical path length of 15-20 km. This extremely long path length allows the measurement of all three gas species with very high precision even at ppm levels, using inexpensive, compact, and highly reliable near-infrared laser sources. The G1301 employs a sophisticated wavelength monitoring and control system, unique to Picarro, that delivers pinpoint wavelength targeting on a microsecond timescale, allowing full nonlinear spectral analysis that delivers gas concentration measurements with unprecedented accuracy and precision, with extremely low cross talk. Furthermore, the advanced temperature and pressure control loops stabilize the spectroscopic signatures, giving the G1301 unmatched stability and accuracy.

In the G1301, separate and distinct spectral lines are used for each measured species. The lines have been carefully selected for high precision, and are free from interference from other nearby spectral lines of other atmospheric constituents. At a given temperature and pressure (which are stabilized in the G1301 to within 10 mK and 0.05 Torr of the internal set points, respectively), and in a given gas matrix, the characteristics of these spectral lines do not vary; the line strength and line shape are intrinsic properties of the target molecule. That fact combined with the Beer-Lambert law, which dictates that the absorption per unit length at the peak of a spectral line is proportional to the concentration of molecules in the gas sample, means that the response of the instrument is incredibly linear to increases in concentration.

A critical assumption in the above analysis is that the gas matrix does not change. The gas matrix in particular has a strong effect upon the line shape. Different gases have different broadening cross-sections, and therefore broaden the spectral line to varying degrees; for example, 1 ppm of carbon dioxide in nitrogen has a broader line with lower peak height than 1 ppm of carbon dioxide in oxygen. For most variations in ambient air, these effects are negligible, because the mixing ratios of most gases do not vary by a large amount. However, variations in atmospheric water vapor content can be extremely large, ranging from a few ppm to 4 %v. The line broadening effect of this variability must be accounted for on all three species to properly determine the dry-gas mixing ratios for carbon dioxide and methane.

Experimental Determination of the Water Vapor Correction for the G1301

Experimental Methods

There are three major contributions to the water vapor correction to the reported carbon dioxide and methane from the Picarro G1301 Analyzer.

- The dilution effect
- variation in the line broadening of the carbon dioxide and methane lines due to varying water vapor concentration
- nonlinearity of the reported water vapor concentration due to self-broadening of the water vapor line

It is straightforward to experimentally measure the overall water vapor correction factor for both carbon dioxide and methane. Several external groups have performed similar experiments by humidifying a known dry gas source and comparing the reported concentrations from the G1301 of carbon dioxide and methane to the known standard values. In Fig. 1, the apparatus used at the Max Planck Institute in Jena for measuring the water vapor correction factor is shown².

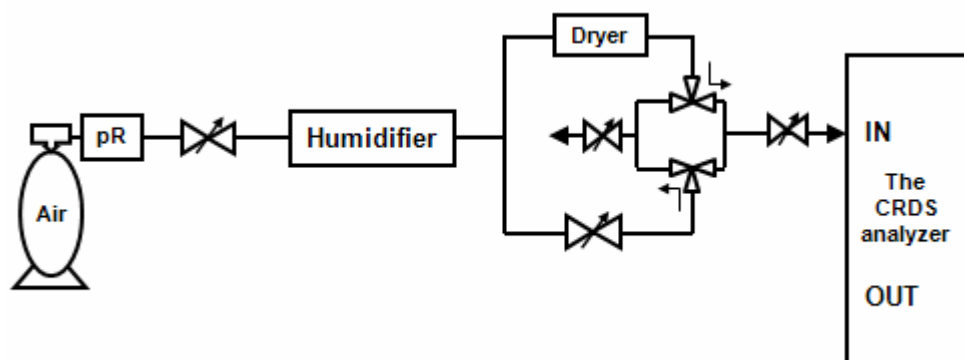

Figure 1: Diagram of experiments to derive water vapor correction functions².

Gas from an ambient air tank is supplied to a humidifier. After it is humidified, the gas is split into two paths, one with and the other without a magnesium perchlorate chemical dryer. Care is taken to ensure that the water reservoir and the chemical drying system do not introduce systematic errors into the measurement. The instrument flow is switched between humid and dry gas streams every five minutes to remove the effects of instrument drift.

The humidifier is sequentially set to dew points 0 °C, 5 °C, 10 °C, 15 °C, 20 °C, 25 °C, 30 °C and 35 °C, corresponding to measured water vapor mixing ratios from 0.6 % to 6 %. The experiments are done in a temperature-controlled room (up to 38 °C) to prevent water vapor from condensing on the walls of tubing before flowing into the CRDS analyzer.

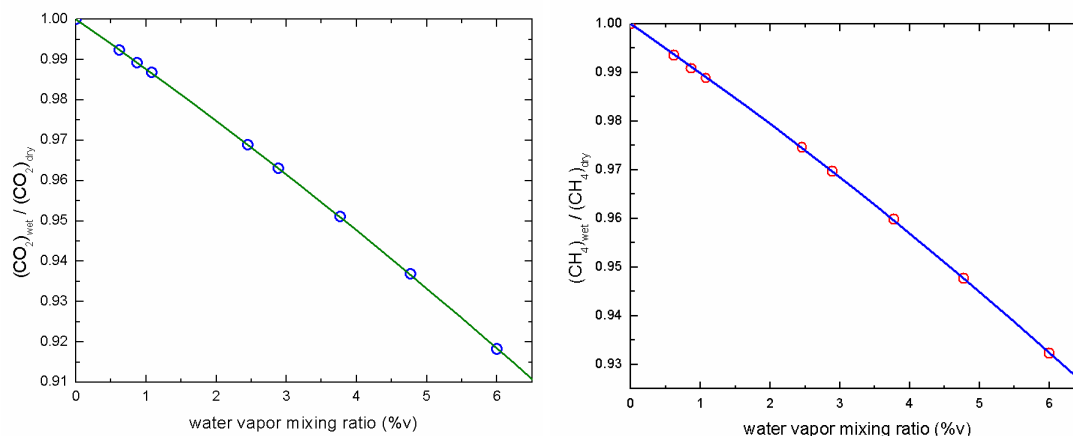

Figure 2 a) - b) Quadratic fit of CO₂wet/CO₂dry and CH₄wet/CH₄dry vs. H₂O mixing ratios^b.

The ratio of the mixing ratios in the wet and dry gas streams are plotted as a function of water vapor concentration, and the resulting data are fit to quadratic equations^b:

$$\frac{(CO_2)_{wet}}{(CO_2)_{dry}} = 1 + aH_{rep} + bH_{rep}^2 \quad \text{and} \quad (1)$$

$$\frac{(CH_4)_{wet}}{(CH_4)_{dry}} = 1 + cH_{rep} + dH_{rep}^2 \quad (2)$$

In these expressions, H_{rep} is the water vapor mixing ratio (in %v) as reported by the G1301. From the data set above, we find the following values for the fit constants:

parameter	value
a	- 0.01200 ± 0.00009
b	- 2.674 ± 0.18 x 10 ⁻⁴
c	- 0.00982 ± 0.00006
d	- 2.393 ± 0.1 x 10 ⁻⁴

The residual errors of the fits were below 0.05 ppm for CO₂ and 0.8 ppb for CH₄.

Note that these expressions are self-contained transfer functions relating the dry carbon dioxide (or methane) mixing ratio to the wet carbon dioxide (or methane) mixing ratio to the *reported* water vapor mixing ratio. These latter two values are simply outputs of the instrument— they do not require calibration of the carbon dioxide (or methane) or the water vapor measurements prior to correction. The resulting dry carbon dioxide (or methane) mixing ratio can be then properly calibrated against NOAA or any other concentration scales. This greatly simplifies the quantification and implementation of the correction factor – all that needs to be done is to

^b The different water vapor correction factors are all fit well by this functional form (see theoretical analysis, below)

perform a simple humid and dry gas stream experiment, and measure the correction factor directly.

Survey of water corrections

At least three different groups have performed similar experiments to quantify the water correction factor, using different methods, on different G1301 instruments. Here we summarize the results of three such investigations, performed at the Max Planck Institute in Jena, Germany², LSCE in Paris, France³, and by Metcon in Königstein, Germany⁴. These results are summarized in the table below:

Table 1: comparison of water vapor correction factors from three different experimental investigations:

Group	Method	CO ₂ – linear / quadratic terms	CH ₄ – linear / quadratic terms	Water vapor range
MPI – Jena	Single instrument - humidification and dehumidification of a gas standard	-0.01200 / - 0.0002674	-0.00982 / -0.000239	0.6 – 6 %v
LSCE	Two instruments – single humid and dehumidified gas stream	-0.01261 / (-)	-0.0102 / (-)	1 – 1.8 %v
Metcon	Single instrument - humidification and dehumidification of a gas standard	-0.0130 / (-)	-0.0108 / (-)	0 – 3 %v

There are small differences between the linear terms of these three results. However, note that for this table we have included the quadratic term only for the MPI results. We do this only because the uncertainty of the quadratic term for the other two data sets is larger than for the MPI quadratic term, simply because the range of water concentration values is narrower for the other two data sets. This large uncertainty hampers our ability to compare the three data sets side by side. Therefore, for the purposes of this comparison, we have applied only linear fits to the LSCE and Metcon data sets. If we take the full quadratic model described by the MPI data, and fit a linear function to this quadratic model over the ranges 1 – 1.8 %v (the LSCE water vapor range) and 0 – 3 %v (the Metcon water vapor range), we find that the slope of this data is given by -0.01275 and -0.01279 for carbon dioxide, respectively, which are very close to the linear coefficients derived from the LSCE and Metcon data sets of -0.01261 and -0.0130. Similarly, for methane, the slopes derived from the MPI quadratic model are given by -0.01049 and -0.01053, which are nearly the same as the observed linear slopes of -0.0102 and -0.0108.

Note that an error in the linear coefficient for carbon dioxide of 0.0001 corresponds to an uncertainty in the dry-gas carbon dioxide mixing ratio of 150 ppb, for a range of water vapor from 0 – 4 %v. For methane, this same uncertainty of 0.0001 on the linear coefficient leads to an uncertainty of 0.8 ppb, for 0 – 4 %v water vapor. This remarkably good agreement between all three experiments, measured on multiple instruments and using differing experimental techniques, is a powerful indication of the reproducibility of the correction factor from instrument to instrument.

Looking more closely at the data, we can make two clear observations:

- While the linear correction factor for methane very nearly follows the simple relationship expected for the dilution effect (where c should equal -0.01 exactly), the linear correction factor for carbon dioxide deviates significantly from a simple dilution model.
- There is a small but clearly observable quadratic dependence to the correction factor which becomes significant in highly humid gas streams (above about 1 % v). The quadratic coefficient is nearly the same for carbon dioxide and methane, despite differences in the linear term, suggesting that the quadratic error stems from the same source for both gases.

In the following section, we present a derivation of the sources of these water vapor correction factors from first principles, and compare these predictions with the observed data.

Derivation of the Water Vapor Correction for the G1301

Theoretical Background

For climate modeling, dry-gas mixing ratios for carbon dioxide and methane are the most useful physical quantities to report; variability in these mixing ratios, due to fluctuations in water vapor due to evaporation and condensation processes, only masks the underlying atmospheric carbon inventories. The wet- and dry-gas mixing ratios are related by the following simple expression:

$$\frac{C_{wet}}{C_{dry}} = 1 - 0.01H_{act} \quad (3)$$

where C is the mixing ratio of carbon dioxide or methane (the same equation holds for each), and H_{act} is the actual water mixing ratio (in % v). The challenge of implementing even this simple equation becomes immediately apparent: the water concentration must be known to a high degree of accuracy and precision to support a high degree of accuracy in the measured dry gas concentrations. For example, to maintain an uncertainty of less than 50 ppb on a 400 ppm carbon dioxide measurement, the water vapor measurement must be *accurate* (not just precise) to within 0.0125 % v, or 125 ppm.

A second important effect that can cause a systematic shift in the reported carbon dioxide and methane mixing ratio is the effect of line broadening. There are three principle mechanisms that determine the spectral line shape for single isolated ro-vibrational lines (such as the lines used in the G1301)⁵:

- Doppler Broadening: For a given gas sample, molecules are always in motion. Some are moving in the direction of the sampling light beam, some are moving opposite the direction of the light beam. These relative motions produce a slight frequency shift of the

optical transition due the Doppler Effect. At low pressures, the Doppler broadened line shape approaches a Gaussian distribution. The width of the distribution is related to the velocity of the molecule.

- Lorentzian Broadening: The transition frequency of a given molecule is a fundamental quantity of the molecule, and is determined by the mass of the constituent atoms and the strength of the binding forces between the atoms. However, the structure of the molecule is disturbed by collisions with other nearby gas molecules, leading to a broadening of the line that is proportional to the pressure of the background gas. The Lorentzian line shape is parameterized by the variable y , the Lorentzian line broadening parameter. When both Doppler broadening and Lorentzian broadening are taken into account, the line shape follows a Voigt profile.
- Line Narrowing: The Voigt profile is a commonly-used spectral line profile, but for high-precision spectroscopy, an effect called line narrowing becomes important. At very low pressures, a Doppler line shape is adequate for modeling the spectral line, but at elevated pressures, there are enough energy-exchanging collisions to distort the Gaussian Doppler-broadened line shape. This effect tends to narrow the line, causing an increase in the peak of the line at the expense of the wings. There are several different models for this line narrowing effect, but they are difficult to distinguish experimentally. In the Picarro G1301, we use a line shape called a Galatry profile, a common model which incorporates the line narrowing effect. There is a single additional parameter called z , the Galatry line-narrowing parameter. In a fixed background gas, this parameter, like the Lorentzian parameter y , is proportional to gas pressure.

The Doppler broadening coefficient is an intrinsic property of the analyte molecule, and does not depend on the constituents of the background gas matrix. However, the Lorentzian broadening and Galatry line narrowing parameters, y and z , do depend both on the analyte gas *and* on the constituents of the background gas matrix. Furthermore, since y and z are derived from fundamentally different processes, they are essentially independent of each other for different gas background species. However, because line narrowing represents a small correction to the overall line shape, we have found that to model the data properly it is adequate to set z to be proportional to y .

The line broadening parameter y has a given value for a given spectroscopic absorption line in a specific gas mixture, at a given temperature and pressure. For example, for the carbon dioxide line used in the G1301, y has one value for 400 ppm of carbon dioxide in dry nitrogen and another value for 400 ppm of carbon dioxide in dry oxygen.

For simple multi-component mixtures of N gases, the line width parameter y for the mixture (for a given spectral absorption line of a given species) is given by the sum of the pure gas line width parameters^c, weighted by the mixing ratios:

$$y_{eff} = \sum_{i=1}^N \chi_i y_i \quad (4)$$

where χ_i is the mixing ratio and y_i is the pure gas line width parameter for the i^{th} gas component. It is important to remember that one of these gases in the sum is the analyte itself – every gas has a so-called self-broadening term, important at elevated concentrations, which corresponds to the fact that the line shape parameters of the analyte in no background (i.e., a mixing ratio for the analyte of 100%) can be different than the analyte in air or nitrogen or any other mixture.

The above relationship can be used to understand a variety of potential cross-talk issues; however, in this paper, we restrict the discussion to the effect of variable water vapor on the measurement of the mixing ratios of carbon dioxide, methane, and water vapor itself. We express ambient air by the following expression for the Lorentzian parameter:

$$y_{eff} = \chi_{O_2} y_{O_2} + \chi_{N_2} y_{N_2} + \chi_{Ar} y_{Ar} + \chi_{H_2O} y_{H_2O} + \chi_{trace} y_{trace}, \quad (5)$$

Here, y is the line width parameter for any of the three analyte gases measured by the G1301. All the minor constituents of air, including carbon dioxide and methane, are combined into the single term $\chi_{trace} y_{trace}$, which is the sum of the product of the single-gas coefficients and the mixing ratios. For realistic conditions, the pure-gas line width parameters (defined above) do not vary dramatically from gas to gas (generally less than a factor of two), and the mixing ratios do not vary by much ($\ll 100$ ppm in the worst case, and generally below 1 ppm), so that this term can be considered constant without causing errors in the measured analyte mixing ratios in excess of 1 part in 10,000 of the measurement (40 ppb for carbon dioxide and 20 pptv for methane). In this paper, we will ignore variations in this term.

Similarly, for typical ambient conditions, the first three terms also do not vary significantly, and can be combined into a single term $\chi_{inert} y_{inert}$ ^d. We can then combine all the (essentially) non-varying, non-volatile components into a single term, $\chi_{dryair} y_{dryair}$, yielding this expression:

^c The pure gas line width parameter is the value as measured in a pure single gas doped with a vanishingly small concentration of the analyte gas.

^d We will consider the effect of variations in the oxygen / nitrogen / argon balance in future work. For ambient measurements, the effects of this variability on the carbon dioxide and methane mixing ratios can be neglected in almost all situations, but these effects may need to be considered when using synthetic gas mixtures as calibration standards.

$$y_{eff} = \chi_{dry\ air} y_{dry\ air} + \chi_{H_2O} y_{H_2O} \quad (6)$$

Finally, this expression holds for y for *each* analyte species carbon dioxide, methane, and water vapor. We can then write the following three equations:

$$(y_{CO_2})_{eff} = (1 - \chi_{H_2O})(y_{CO_2})_{dry\ air} + \chi_{H_2O}(y_{CO_2})_{H_2O} \quad (7)$$

$$(y_{CH_4})_{eff} = (1 - \chi_{H_2O})(y_{CH_4})_{dry\ air} + \chi_{H_2O}(y_{CH_4})_{H_2O} \quad (8)$$

$$(y_{H_2O})_{eff} = (1 - \chi_{H_2O})(y_{H_2O})_{dry\ air} + \chi_{H_2O}(y_{H_2O})_{H_2O} \quad (9)$$

In this nomenclature, the subscript inside the parenthesis is the analyte molecule and the molecule outside the parenthesis is the background matrix. For example, $(y_{CO_2})_{dry\ air}$ is the Lorentzian broadening parameter of the carbon dioxide absorption line in a background of dry air, and $(y_{H_2O})_{H_2O}$ is the Lorentzian broadening parameter of the water absorption line in the presence of 100% water vapor^e.

Using the high-precision wavelength monitor in the G1301, and performing post-analysis on the data collected by the instrument, the pure gas line shape coefficients can be measured. The system of expressions, above, together with Galatry line models for the lines, allow us to predict the variation of the peak height of the analyte absorption features, and thus enable us to predict the concentration correction factor.

Spectroscopic Analysis – Water Vapor

We begin with analysis of the water vapor measurement on the G1301. The G1301 family of instruments uses a single water vapor ro-vibrational line in the near infrared region of the spectrum. The G1301 is built upon what is essentially a high resolution optical spectrometer, so it is a straightforward matter to modify the instrument software such that the raw spectral data are processed such that not only the peak height but the Lorentzian broadening term is provided as an output from Picarro's proprietary nonlinear spectral fitting algorithm. We have performed detailed measurements of the Lorentzian broadening of this line as a function of water vapor mixing ratio in a balance of zero air; the data are displayed in the Fig. 3, along with a simple linear fit. The observed shift in the width of the line with increasing water vapor concentration leads to a small but not insignificant nonlinearity in the measurement of water vapor in the G1301. As the water vapor concentration increases, the line shape becomes broader, which in turns decreases the peak height^f. Therefore, the G1301 will tend to underestimate the water concentration, especially at elevated concentrations. Extrapolating the broadening coefficient to

^e 100%v water vapor is not a practically achievable condition at the operating temperature and pressure of the optical cavity in the G1301. However, we can measure y_{eff} at several physically realistic water mixing ratios, which can then be extrapolated to the pure-gas broadening parameter using the linear relationship for y_{eff} described above.

^f At constant mixing ratio, the peak area of a given spectral line is conserved.

100 %v water vapor concentration, we find that $(y_{H_2O})_{H_2O}$ is equal to 3.943. Using the expression for y_{eff} above and the Galatry line shape model, we can predict the dependence of the actual water vapor concentration upon the measured water vapor concentration. These data are shown in Fig. 4, together with a quadratic fit. The curve is slightly nonlinear, with a quadratic coefficient of 0.02525. This correction becomes significant only above 2 %v of water.

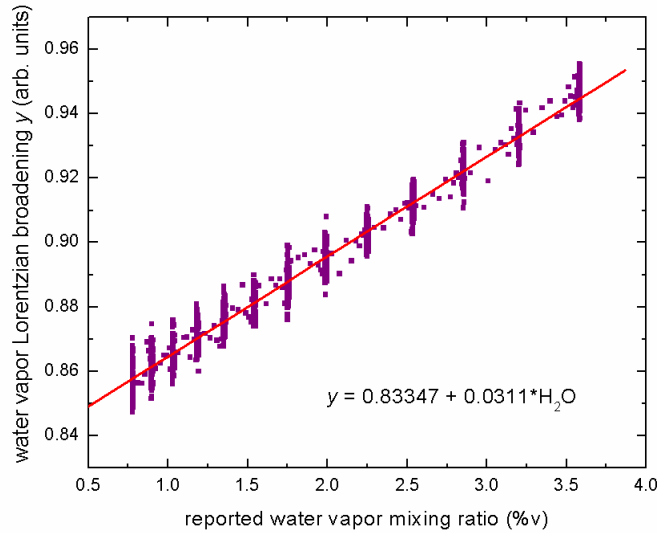

Figure 3: Lorentzian broadening parameter for the water vapor line, as a function of reported water vapor concentration. The line gets broader with increasing mixing ratio due to the self-broadening effect.

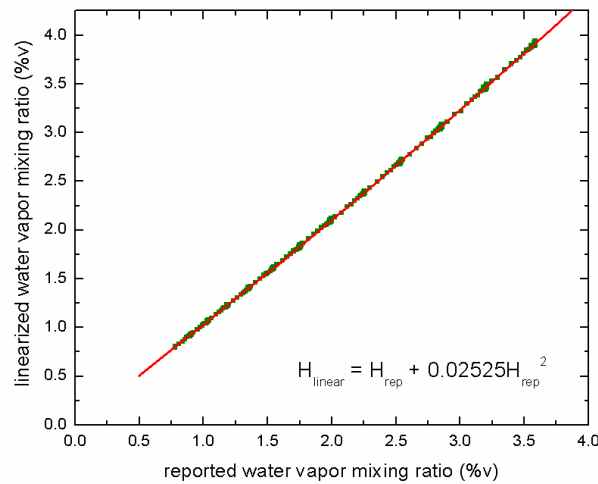

Figure 4: Water vapor concentration, corrected for line shape self-broadening effects. Note the slight nonlinearity, represented by the quadratic coefficient of 0.02525.

All G1301 instruments carry the same water vapor calibration coefficient that relates the height of the water vapor line to the water vapor mixing ratio. This calibration coefficient was derived from cross-calibration with a calibrated $^1H^2HO$ line, but unfortunately, an error in the isotope calibration lead to an inaccuracy in the water vapor calibration constant. More recently, a single

G1301 instrument has been calibrated against a calibrated water vapor instrument based on dew point mirror technology (Dewmet, Michell instruments Ltd.,UK) at the Max Planck Institute in Jena, Germany. The instrument was calibrated over a range of water vapor mixing ratios from 0.7 – 3.0 %v, and the data are shown in Fig. 5, along with a quadratic calibration curve of the following functional form:

$$H_{actual} = 0.772(H_{reported} + 0.02525H_{reported}^2) \quad (10)$$

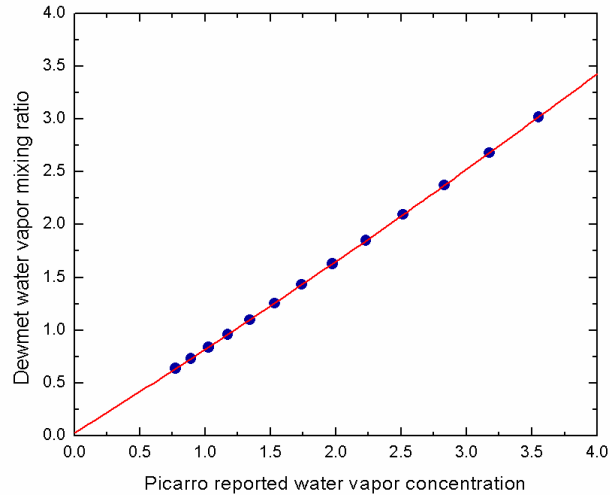

Figure 5: G1301 water vapor calibration using a calibrated dew point analyzer at MPI - Jena. The red line is a quadratic fit of the form $H_{actual} = 0.772(H_{reported} + 0.02525H_{reported}^2)$.

This equation self-consistently preserves the calibration as measured by the dew point instrument, and captures the small nonlinearity caused by the self-broadening of the water vapor absorption line. This expression should be used to correct the water vapor mixing ratio as reported by the G1301.

Spectroscopic Analysis – Carbon Dioxide

We now proceed to the water vapor correction for carbon dioxide. The expression governing y_{eff} is written below:

$$(y_{CO_2})_{eff} = (1 - \chi_{H_2O})(y_{CO_2})_{dry\ air} + \chi_{H_2O}(y_{CO_2})_{H_2O} \quad (11)$$

Using the apparatus shown in Fig. 1, we have made measurements of y_{eff} as a function of measured water vapor concentration, using similar analysis techniques as was performed on the water vapor absorption line. These data are shown in Fig. 6, along with a linear fit.

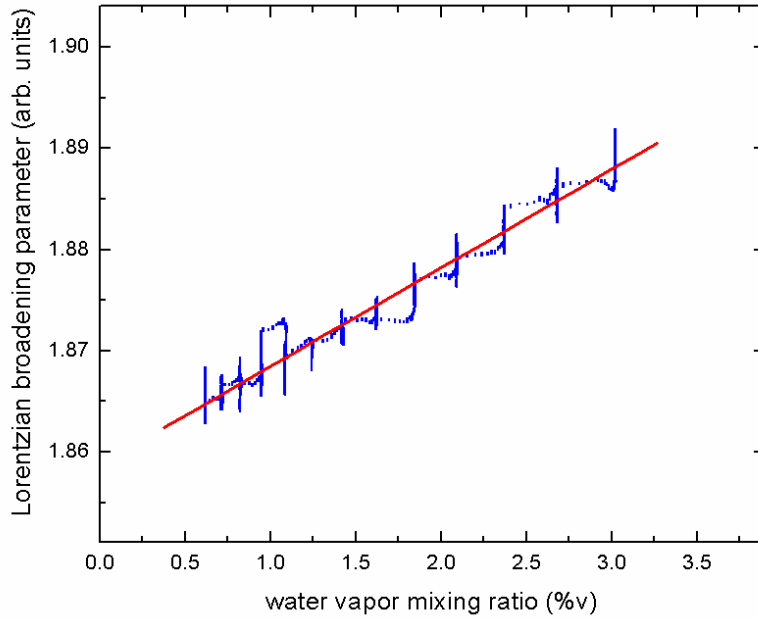

Figure 6: Lorentzian broadening parameter y as a function of measured water vapor concentration (which has been corrected for self-broadening as described above). The precision (standard deviation) of the width parameter is 0.0039. The fit to the data is of the form $y = A + BH$, where $A = 1.8588$ and $B = 0.00982$.

Extrapolating this data to 100 %v water vapor mixing ratio gives a $(y_{CO_2})_{H_2O}$ of 2.8408. Increasing the Lorentzian broadening parameter tends to decrease the peak height of the carbon dioxide line for a given mixing ratio, leading to a reported value that is smaller than the true mixing ratio. Using the expression for y_{eff} above and the Galatry line shape model, we can predict the dependence of the correction factor for the carbon dioxide mixing ratio as a function of the water vapor mixing ratio.

$$\frac{(CO_2)_{wet-reported}}{(CO_2)_{dry-broadening\ only}} = 1 - 0.00493H_{act} + 9.03 \times 10^{-6} H_{act}^2 \quad (12)$$

Combining this correction factor for broadening with the dilution correction, we arrive at the following expression relating the wet and dry measurements of the carbon dioxide mixing ratio (in which only the linear and quadratic terms are reported here):

$$\frac{(CO_2)_{wet-reported}}{(CO_2)_{dry-actual}} = 1 - 0.01493H_{act} + 5.83 \times 10^{-5} H_{act}^2 \quad (13)$$

Finally, we may then insert the correction to the water vapor mixing ratio $[H_{actual} = 0.772(H_{reported} + 0.02525H_{reported}^2)]$ to derive the overall correction factor relating the correct dry mixing ratio for carbon dioxide to the reported carbon dioxide and the reported water concentration (again, only keeping the linear and quadratic terms):

$$\frac{(CO_2)_{wet-reported}}{(CO_2)_{dry-actual}} = 1 - 0.01152H_{rep} - 2.59 \times 10^{-4} H_{rep}^2 \quad (14)$$

It is important to remember that this analysis relies on measurements only the width of the lines and direct water vapor calibration, not the spectral peak heights. The derivation above thus provides a measure of the correction factor relating the wet and dry carbon dioxide mixing ratios to the reported water vapor concentration that is independent of the direct measurement presented in the prior section. Yet, the two methods agree remarkably well, as shown in the table below:

Table 2: Comparison of the direct measurement of the water vapor correction for carbon dioxide to theory.

<i>Parameter</i>	<i>Direct Measurement (MPI data)</i>	<i>Theoretical prediction</i>
Linear term	- 0.01200 ± 0.00009	- 0.01152 ± 0.0005
Quadratic term	- 2.674 ± 0.18 x 10 ⁻⁴	- 2.59 ± 0.5 x 10 ⁻⁴

The agreement between the direct measurement and the theoretical prediction gives us confidence that we have captured the important corrections by including the dilution effect, the self-broadening of the water vapor line, and the Lorentzian line broadening for the carbon dioxide line. Improved agreement might be possible by modeling the Galatry line narrowing parameter separately from the Lorentzian broadening parameter, but the data were not of sufficient quality to support this analysis. Note that the errors in the theoretical prediction are much larger than for the direct measurement. The biggest contributors to this error are a) the absolute calibration of the water vapor measurement, and b) the noise in the measurement of the Galatry line shape parameters as a function of water vapor mixing ratio. The direct measurement does not suffer from either of these uncertainties.

Spectroscopic Analysis – Methane

The water vapor correction for methane can in principle be derived using similar techniques. However, unlike the carbon dioxide line, which is a single isolated transition, the methane feature employed in the G1301 is actually a complex of four separate transitions that are too close together to separate at the operating temperature and pressure of the instrument. It is impractical to model each of the four lines separately – there is simply not enough information in the spectrum to stably and reliably fit the four lines independently. Because they are different transitions, they likely have different dependences of their broadening factors on water vapor mixing ratio. Furthermore, in addition to Lorentzian broadening, spectral lines can also exhibit small wavelength shifts as the background gas varies. This effect is unimportant for isolated lines such as carbon dioxide and water vapor, but it is important for line clusters such as methane, where relative shifts between the lines can change the fundamental shape of the composite line. It is therefore not possible to provide a complete model of the line shape effects for methane as we did above for carbon dioxide. Instead, we must rely on the direct

experimental measurement of the methane correction factor. However, the superb agreement obtained on the carbon dioxide measurement gives good reason to believe that the methane correction factor also results from the dilution and broadening effects considered above.

Recipe for Water Vapor Correction of the Picarro G1301

For each of the three mixing ratios reported by the G1301 (carbon dioxide, methane, and water vapor), a correction factor must be applied to counteract the effects of water vapor on the measurements. In the case of water vapor itself, the primary error is due to self-broadening of the water vapor spectral line. The correction factor for water vapor takes the following form:

$$H_{actual} = 0.772(H_{reported} + 0.02525H_{reported}^2) \quad (15)$$

This correction factor is derived directly from spectroscopic measurements, with the overall calibration constant given by comparison to a calibrated water vapor dew point meter over the range 0.6 – 3.0 %v (see above).

For carbon dioxide and methane, correction factors must be applied to obtain the dry gas mixing ratios. Performed correctly, these methods provide the most accurate means of characterizing the water correction on a specific instrument. Many methods can be used to directly measure these water vapor correction factors. The technique outlined in the “Experimental Methods” section, above, has the advantage that it is both highly accurate (due to ability to frequently insert dry gas with the same carbon dioxide and methane concentrations) and can generate data over a wide range of water vapor mixing ratios (due to the elevated temperature of the environment). However, it is not a simple experiment to implement in the field.

We can propose a simpler apparatus for measuring the water vapor correction factors, which is shown in the left-hand panel of Fig. 7. In this system, the gas from a known bottle is humidified by transferring the gas to the instrument via a hydrophobic Teflon membrane filter. A small volume of liquid water (~200 μ liters) is injected into the upstream side of the filter. The water does not pass through the filter in liquid form – only water vapor can pass through the membrane, thus humidifying the air. At ambient temperature and a flow of about 250 sccm (the standard for the G1301), the air is humidified to about 0.5 %v. By heating the filter, the air can be humidified from 0.5 %v up to 3 %v, in a matter of minutes. In the right-hand panel of Fig. 7, we show a typical water vapor response curve generated by this setup, from which the water vapor correction factors for carbon dioxide and methane can be easily generated.

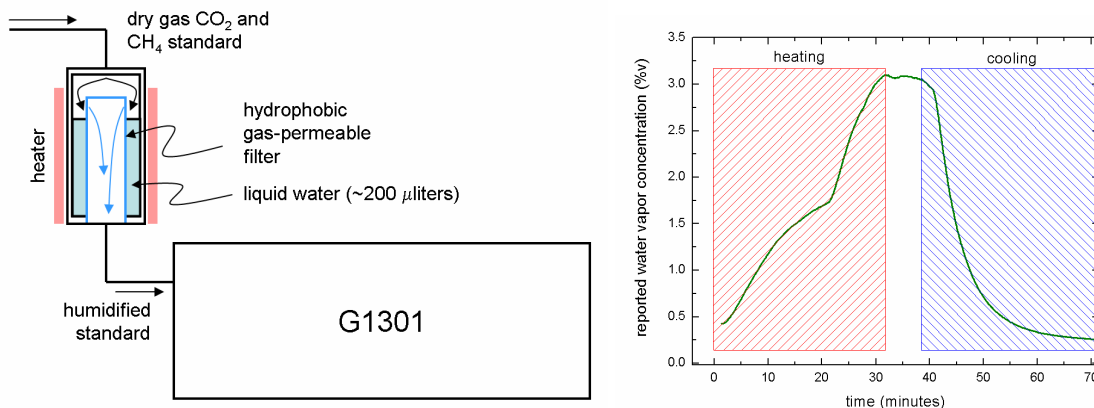

Figure 7: A simple apparatus for measuring the water vapor correction factors for the G1301, and typical results for the reported water vapor concentration.

However, we recognize that it is not always practical or convenient to perform this experiment frequently. Given the reproducibility of the correction factors as measured by three different groups, it is certainly possible to use a single set of correction factors across all G1301 instrumentation. Because of the quality of the MPI-Jena data, and the large water vapor range over which the correction factors were measured, we recommend that the MPI-Jena quadratic equations be applied as correction factors on the G1301 instrumentation:

$$\frac{(CO_2)_{wet}}{(CO_2)_{dry}} = 1 + aH_{rep} + bH_{rep}^2 \quad \text{and} \quad (16)$$

$$\frac{(CH_4)_{wet}}{(CH_4)_{dry}} = 1 + cH_{rep} + dH_{rep}^2 \quad (17)$$

where $a = -0.01200$, $b = -2.674 \times 10^{-4}$, $c = -0.00982$, $d = -2.393 \times 10^{-4}$. It is important to note that these correction factors are in terms of *reported* water vapor values, not *actual* water vapor values. Thus, the correction factors are not dependent upon the uncertainty inherent in the measurement of the actual water vapor mixing ratio, and are instead tied directly to the individual spectroscopic features. In this way, we fold all effects (dilution, broadening, line-narrowing, and the independent absolute calibrations of all three species) into the above pair of equations, and remove the accumulation of errors that result from treating each effect separately. The final calibration of all three gases should be performed after these correction factors are applied, so that variations in the calibration constants do not affect the integrity of the correction equations.

We estimate the errors introduced by applying equations derived on a single instrument to the entire family of G1301 instrumentation by comparison of the three separate measurements. For carbon dioxide, the average difference of the linear coefficient among the three data sets is 0.000215. This corresponds to an error of 80 ppb / %v of water vapor on a 380 ppm signal. This is a small, but not insignificant, error in the measurement. For methane, the average difference of the linear coefficient among the three data sets is 0.00028, which corresponds to an error of 0.56 ppb / %v of water vapor on a 2000 ppb signal. However, these values may be over-estimates: it

is important to remember that the precision of the correction factors between these experiments is limited by the precision of the carbon dioxide and methane measurements – the quality of the data simply may not support a more accurate estimate of the error of the correction equation.

We may estimate this error in another way, by looking at the stability of the calibration factor for water vapor from instrument-to-instrument, as determined at the Picarro factory. Unfortunately, due to the volatility of water vapor, it is not straightforward to deliver a known accurate sample of water vapor to the instruments at the factory. However, the measurement of water vapor is based upon an optical absorption feature, just as the carbon dioxide and methane measurements are. This means that the same degree of consistency that we observe on the calibration constants for these gases should be applicable to the water vapor calibration curve. The carbon dioxide and methane calibration constants vary from instrument to instrument with a standard deviation of about 1 part in 300^g. This corresponds to an uncertainty in the water vapor measurement of 1 part in 300, which in turn would lead to an error in the dry carbon dioxide mixing ratio (as predicted by the water vapor correction factor) of about 16 ppb / %v water vapor for carbon dioxide, and about 0.072 ppb / %v water vapor for methane. These estimates are significantly smaller than the estimates above based on the survey of different direct measurements of the correction factor, and should give hope that a single correction factor may be successfully applied across all instrumentation. However, to obtain the best results, we recommend that the water correction factor be calibrated on every G1301 instrument at the start of life.

The stability of this correction factor over time, on a given instrument, depends directly on the stability of the reported water vapor concentration. However, we may extrapolate the performance of the G1301 water vapor measurement from the performance of the carbon dioxide and methane measurements on that same analyzer, which have been well characterized by Picarro and others. The instruments are guaranteed to be stable to 1 part in 800 over a period of 1 month, and they generally exceed this specification by a substantial amount. Furthermore, due to the nature of the technology, the drift tends to be excursions around a mean value, rather than monotonically increasing or decreasing, over time. If we assume a maximum drift of 1 part in 400 on the water vapor mixing ratio measurement, this corresponds to an error of no greater than 12 ppb / %v of water vapor on a measurement of 380 ppm of carbon dioxide, and an error of 0.05 ppb / %v of water vapor on a measurement of 2000 ppb of methane. These are extremely small errors – we believe that, provided the instruments are calibrated initially and are operating properly, and over a reasonable range of water vapor mixing ratios, the water vapor correction value should be stable over time to within the WMO inter-laboratory comparability requirements for carbon dioxide and methane.

Finally, it is possible to further improve upon the uncertainty in this correction by periodically repeating the water vapor correction measurement, at a single water vapor mixing ratio if not over the entire range. Another possibility (yet to be validated) is to use a proxy, such as the calibration error observed in the carbon dioxide and methane that is obtained from periodic

^g These statistics are based on a survey of the last twenty G1301 instruments built at the Picarro factory.

calibration checks, to track water vapor calibration changes. Many of the minute effects that might affect the water vapor correction factor (temperature drift, pressure drift, e.g.) will affect all the spectroscopic lines measured in the instrument. We expect that such techniques can reduce the uncertainty by perhaps a further factor of two, to 6 ppb / %v of water vapor for carbon dioxide and 0.025 ppb / %v of water vapor for methane. Even in extremely humid gas streams (4 %v), the uncertainty corresponds to just 24 ppb for carbon dioxide and 0.10 ppb for methane.

The expected uncertainty in the water vapor correction factor for different calibration strategies are summarized in the following chart:

Table 3: Measurement uncertainty introduced by the water vapor correction, for different calibration strategies

	Carbon Dioxide @ 380 ppm		Methane @ 2000 ppb	
	1% H ₂ O	4% H ₂ O	1% H ₂ O	4% H ₂ O
Raw data from G1301, without any water vapor correction factor applied	5.2 ppm	21 ppm	22.5 ppb	90 ppb
Picarro-specified water vapor correction factor applied to all instruments	0.08 ppm ^h 0.016 ppm ⁱ	0.36 ppm 0.064 ppm	0.56 ppb 0.072 ppb	2.2 ppb 0.29 ppb
Instrument-specific water vapor correction factor measured at start of	0.012 ppm	0.048 ppm	0.05 ppb	0.20 ppb
Instrument-specific water vapor correction factor measured periodically	0.006 ppm	0.024 ppm	0.025 ppb	0.10 ppb

Keeping in mind the WMO inter-laboratory comparability standards of 0.1 ppm for carbon dioxide (0.05 ppm in the southern hemisphere) and 2 ppb for methane, we arrive at the following concrete recommendations for water vapor correction:

1. Without applying any correction factors, the gas stream must be dried to below 0.01 %v water vapor to achieve less than 50 ppb uncertainty for carbon dioxide, and to less than 0.05 %v water vapor to achieve less than 1 ppb uncertainty for methane.
2. For methane, using the Picarro-specified water vapor correction factor should meet the WMO requirements for all but the most humid gas streams (> 3.5 %v). Measuring the water correction factors for each G1301 at the start of life will certainly improve the uncertainty to well below the WMO standard under all conditions.
3. For carbon dioxide, using the Picarro-specified water vapor correction factor *may* meet the WMO standard, but a more certain strategy is to calibrate the water vapor correction for each G1301 at the start of life.

^h estimated from deviations between MPI-Jena, LSCE, and Metcon data sets.

ⁱ estimated from the expected variability in water vapor calibration constants from instrument to instrument.

4. Periodically measuring the water vapor correction improves the uncertainty dramatically for both gases, but this is required only for the most demanding applications that require lower uncertainty than is given by the WMO inter-laboratory comparability standard.

Conclusion

Picarro's G1301 three-species instrument is a highly accurate and precise analyzer capable of measuring the dry-gas mixing ratios of carbon dioxide and methane with an accuracy that satisfies the WMO inter-laboratory comparability standards, even in very humid gas streams.

Acknowledgements

The author gratefully acknowledges the scientific efforts of Huilin Chen at the Max Planck Institute in Jena, Benoit Wastine of LSCE, and Rainer Schmidt of Metcon GmbH, without whom this work would not have been possible. In addition, the author wishes to thank several scientists for providing guidance and input for this work, including Arlyn Andrews of NOAA, Marc Fischer of Lawrence Berkeley Laboratories, Troy Ocheltree of Kansas State University, and Scott Richardson of Penn State University.

-
- ¹ Crosson, E. R., et al., "A cavity ring-down analyzer for measuring atmospheric levels of methane, carbon dioxide, and water vapor." *Applied Physics B-Lasers and Optics* 92(3): 403-408 (2008).
 - ² Chen, H., Winderlich, J. et al., "High-accuracy continuous airborne measurements of greenhouse gases (CO₂ and CH₄) during BARCA," submitted to *Atmospheric Measurement Techniques* (2009).
 - ³ Benoît Wastine, et al., "Evaluation of the EnviroSense 3000i Analysers for Continuous CO₂ / CH₄ Measurements by CRDS," Rapport CEA-R-6218, Commissariat à l'Énergie Atomique (2009).
 - ⁴ Rainer Schmidt, personal communication (2009).
 - ⁵ *Spectral analysis follows the treatment in* Phillip L. Varghese, et al., "Collisional narrowing effects on spectral line shapes measured at high resolution," *Appl. Optics* 23, 2376 – 2385 (1984).